

JUKI®

model MS-19

High Speed, Chain Stitch, Two-Needle,
Feed-Off-The-Arm, Lap Seam Felling
Industrial Sewing Machine

PARTS * BOOK

REVISION NO. 1

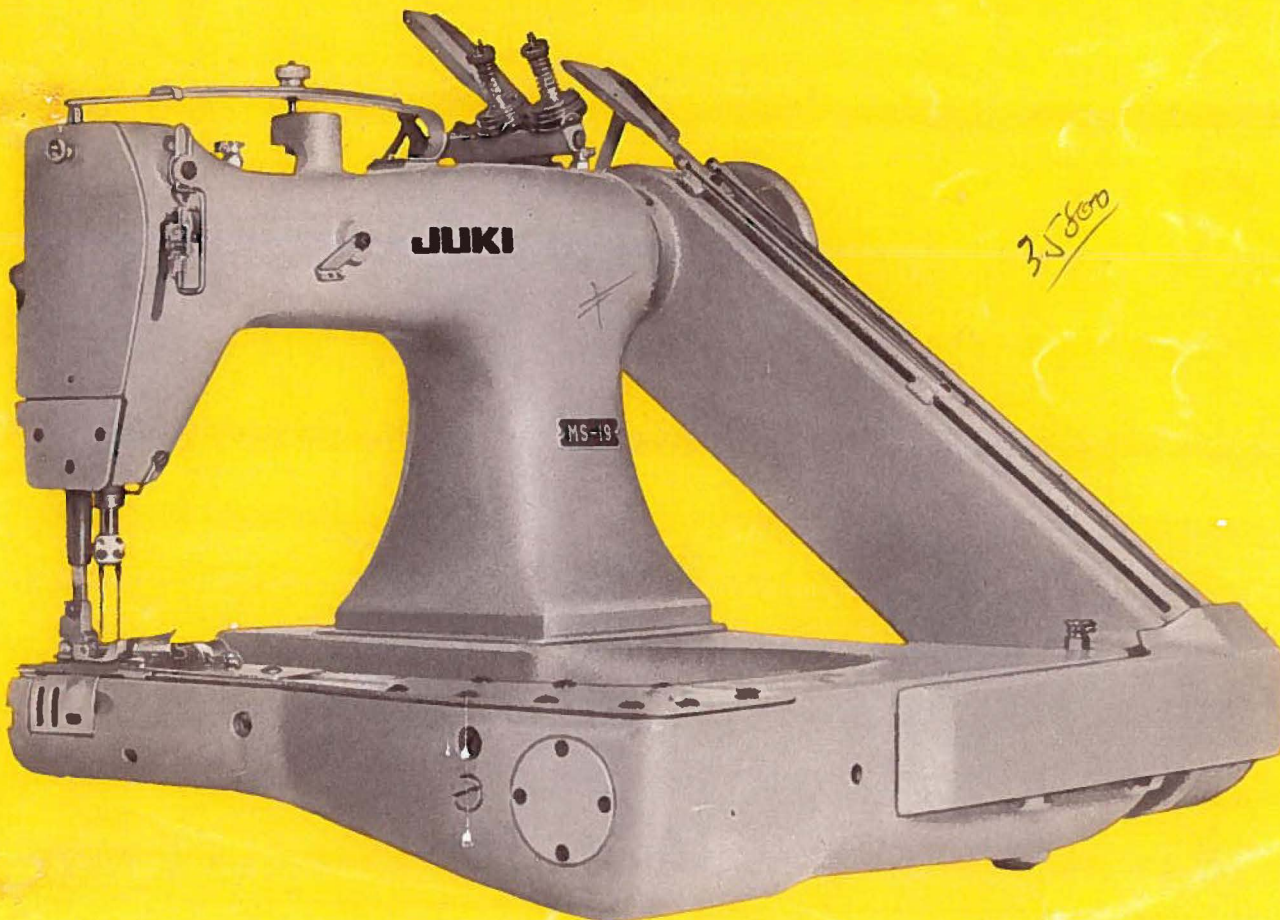

TOKYO JUKI INDUSTRIAL CO., LTD.

From the library of: Superior Sewing Machine & Supply LLC

HOW TO MAKE USE OF THIS PARTS BOOK

1. This is a consolidated PARTS BOOK of Model MS-19.
2. This list is divided, as a principle, into various sections according to the functions of parts and also contains illustrations to assist you visually.
3. For example, if you want some parts for the THREAD TENSION & PRESSER LIFTER COMPONENTS, just refer to the section on "THREAD TENSION & PRESSER LIFTER COMPONENTS" etc.
3. The figures on the illustrations indicate the corresponding numbers on the BOOK.
4. On bits and pieces parts such as screws, etc. the illustration shows only a representative one and so for the required quantity of these parts, refer to the BOOK.
5. Parts marked with * on the the "Ref. No." or "Ref. No." column, mean these parts are one complete assembly unit.
6. The parts under "Amt. Req." column circled by ○ are parts included in the one assembly unit which is marked with * just above these parts.
7. When placing your order, please specify your order by the assembly unit number marked with * under the "Ref. No." column. However, parts whose "Ref. No." column are not circled by ○ can be sold as a single part unit even though the "Amt. Req." column figure is circled by ○.

FOR EXAMPLE

Ref. No.	Part No.	Description	Amt. Req.	
1	B-1111-111-0A0	Name of part	1	Means one assembly unit
2	B-1111-111-000	" "	①	Means this is included in the above B-1111-111-0A0 assembly unit. (This part can be sold as a single unit)
③	B-1112-111-000	" "	①	Means this part is included in the above B-1111-111-0A0 assembly unit. (This part can not be sold as a single unit)

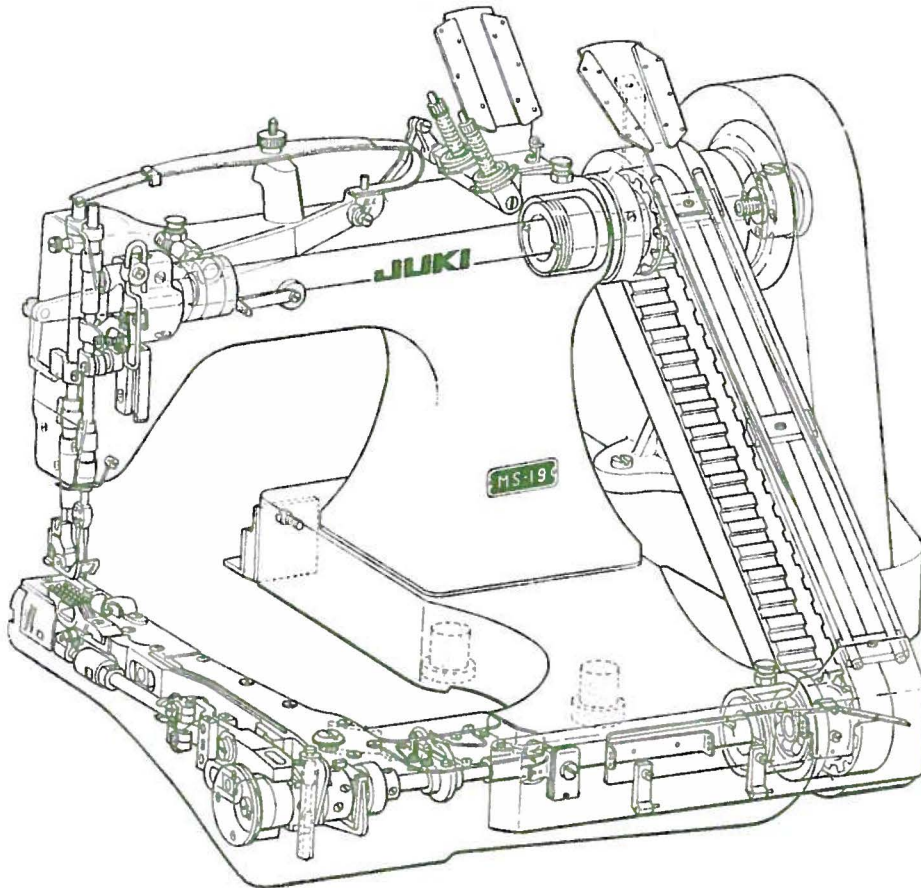

CONTENTS

1. THREAD TAKE-UP & LOOPER THREAD TENSION COMPONENTS	1
2. FRAME & MISCELLANEOUS COVERS COMPONENTS	3
GAUGE SET COMPONENTS	3
3. FEED & LOOPER DRIVING MECHANISM COMPONENTS	4
4. ARM ROTARY SHAFT & BED ROTARY SHAFT COMPONENTS	5
5. THREAD TENSION & PRESSER LIFTER COMPONENTS	6
6. LOOPER MECHANISM COMPONENTS	7
7. PRESSER BAR & NEEDLE BAR COMPONENTS	8
8. NUMERICAL INDEX OF PARTS	9

1. THREAD TAKE-UP & LOOPER THREAD TENSION COMPONENTS

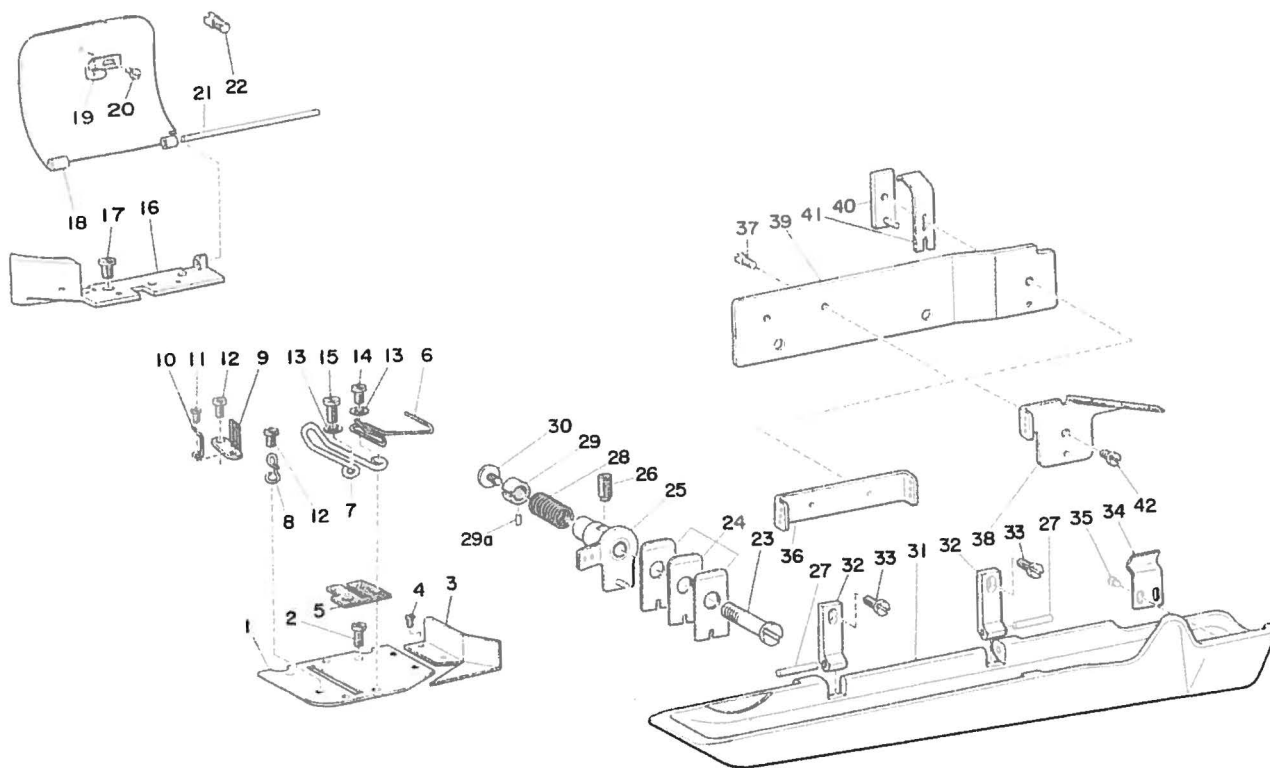

Ref. No.	Part No.	Description	Amt. Req.	Ref. No.	Part No.	Description	Amt. Req.
1	B-2201-019-000	Looper thread take-up stripper plate	1	28	B-2415-019-000	Looper thread tension spring	1
2	SS-7090410-SP	. . . Screw	1	29	B-2414-019-000	Looper thread tension regulating screw stud nut	1
3	B-2202-019-000	. . . Thread guard	1	30	SS-5090710-SP	Screw, for tension regulating screw stud	1
4	SS-6060340-SP	. . . Screw	2	31	B-1113-019-000	Looper thread tube cover	1
5	B-2220-019-000	Looper thread guide (B) cushion	1	32	B-1114-019-000	Looper thread tube cover hinge	2
6	B-2211-019-000	Looper thread guide (A)	1	33	SS-7091110-SP	. . . Screw	2
7	B-2212-019-000	Looper thread guide (B)	1	34	B-1141-019-000	Looper thread tube cover spring (A)	1
8	B-2213-019-000	Looper thread guide (C)	1	35	SS-7060310-SP	. . . Screw	3
9	B-2212-03B-000	Looper thread guide (E)	1	36	B-2413-026-A00	Looper thread guide plate (A)	1
10	B-2214-019-000	Looper thread guide (D)	1	37	SS-2060310-SP	. . . Screw	2
11	SS-6060340-SP	. . . Screw, for (D)	1	38	B-2413-026-B00	Looper thread guide plate (B)	1
12	SS-7090520-SP	. . . Screw, for (C) & (E)	2	39	B-2414-026-000	Looper thread guide plate fixing plate	1
13	WP-0371016-SP	. . . Washer, for (A) & (B)	3	40	B-1144-019-000	Looper thread tube cover spring reinforcing plate	1
14	SS-7090530-SP	. . . Screw, for (A)	1	41	B-1143-019-000	Looper thread tube cover spring (B)	1
15	SS-7090710-SP	. . . Screw, for (B)	2	42	SS-3090710-TP	. . . Screw	1
16	B-2203-019-000	Looper thread take-up stripper plate bracket	1				
17	SS-3090510-SP	. . . Screw	2				
18	B-2207-019-000	Looper thread take-up cover	1				
19	B-2208-019-000	Looper thread take-up cover spring	1				
20	SS-6060210-SP	. . . Screw	1				
21	B-2224-019-000	Looper thread take-up cover pin	1				
22	B-2226-019-000	. . . Locking screw stud	1				
23	B-2416-019-000	Looper thread tension regulating screw stud	1				
24	B-2413-019-000	Looper thread tension plate	3				
25	B-2421-026-000	Looper thread tension guide	1				
26	SS-8151550-SP	. . . Screw	1				
27	B-1115-019-000	Hinge connecting pin	2				

2. FRAME & MISCELLANEOUS COVERS COMPONENTS

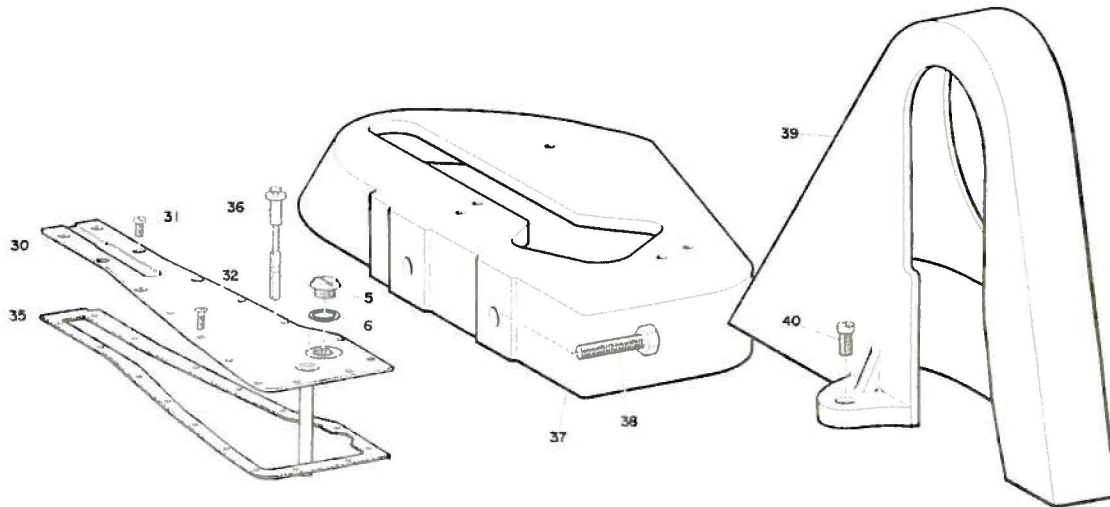
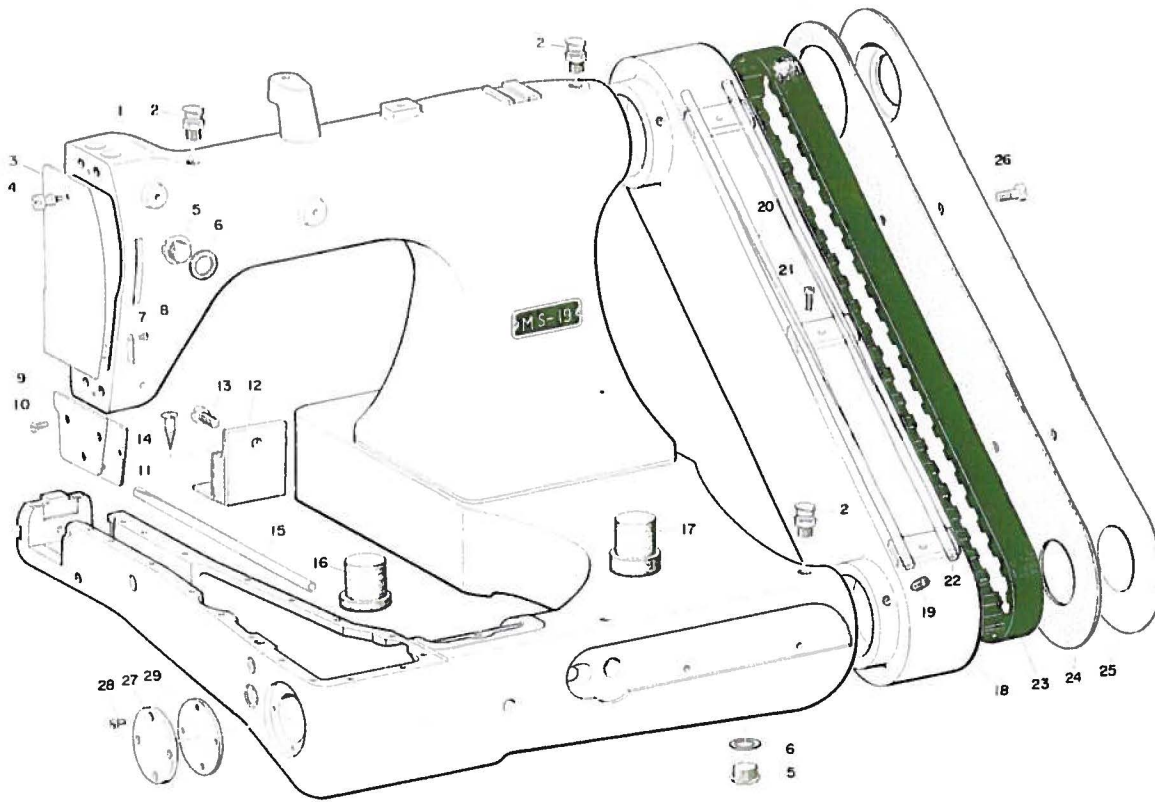

Ref. No.	Part No.	Description	Amt. Req.	Ref. No.	Part No.	Description	Amt. Req.
1	B-1101-019-000	Main frame	1	22	B-241B-019-000	Looper thread tube cap	4
2	B-1155-019-000	Oil cup	3	23	B-1219-019-000	Timing belt	1
3	B-3101-019-000	Face plate, upper	1	24	B-1117-019-000	Sprocket wheel cover gasket	1
4	B-3106-019-000	. . . Screw	1	25	B-1111-019-000	Sprocket wheel cover palte	1
5	B-1139-019-000	Oil reservoir plug screw	3	26	SS-7151210-SP	. . . Screw	2
6	B-1140-019-000	. . . Washer	3	27	B-1805-019-000	Bed rotary shaft front bushing cover	1
7	B-3104-019-000	Face plate pawl spring	1				
8	SS-7060310-SP	. . . Screw	1	28	SS-6090620-SP	. . . Screw	4
9	B-3102-019-000	Face plate, lower	1	29	B-1806-019-000	. . . Gasket	1
10	SS-1090920-SP	. . . Screw	1	30	B-1116-019-0A0	Bed cover assembly	1
11	B-3103-019-000	Gasket, for face plate, lower	1	31	SS-7090B50-SP	. . . Screw	6
12	B-1148-019-000	Rubber cushion (A)	2	32	SS-5091020-SP	. . . Screw	10
13	SS-6151440-SN	. . . Screw A	1	33	B-1120-019-000	Bed cover gasket clamping plate	1
14	SK-3552000-SC	. . . Screw B	1				
15	B-1157-019-000	Looper thread tube (C)	1	34	SS-7060310-SP	. . . Screw	1
16	B-1152-019-000	Rubber cushion (B)	1	35	B-1119-019-000	Bed cover gasket	1
17	B-1156-019-000	Rubber cushion (C)	1	36	B-1134-019-000	Oil gauge stud	1
18	B-1110-019-000	Sprocket wheel cover	1	37	B-1105-019-000	Bed extension	1
19	SS-8660610-TP	. . . Screw	2	38	SS-9284043-CP	. . . Screw	2
20	B-2406-019-0A0	Looper thread tube (A)	1	39	B-1104-019-000	Belt guard	1
21	SS-4091010-SP	. . . Screw	2	40	SS-6151440-SP	. . . Screw	1

GAUGE SET COMPONENTS

(*) Size symbol 1/8"=B (Δ) M (For light weight materials)=A
5/32"=C MH (For medium heavy weight materials)=B
3/16"=D H (For heavy weight materials)=C
7/32"=E
1/4"=F

As the size symbol will be inserted to the part numbers with * mark of the below list and binder symbol to the part numbers with Δ mark, when ordering please specify the respective symbol with the part number.

B-1108-019-*F0	Gauge set (no binder)	B-2513-019-*A0	Looper set
B-1108-019-*FΔ	Gauge set (with binder)	B-2513-019-*00	Looper A
B-1108-019-*00	Needle plate	B-2514-019-*00	Looper B
B-1604-019-*00	Feed	B-2515-019-000	Looper holder
B-1507-019-*A0	Presser foot	B-9100-019-*AΔ	Binder
B-1406-019-*00	Needle clamp		

3. FEED & LOOPER DRIVING MECHANISM COMPONENTS

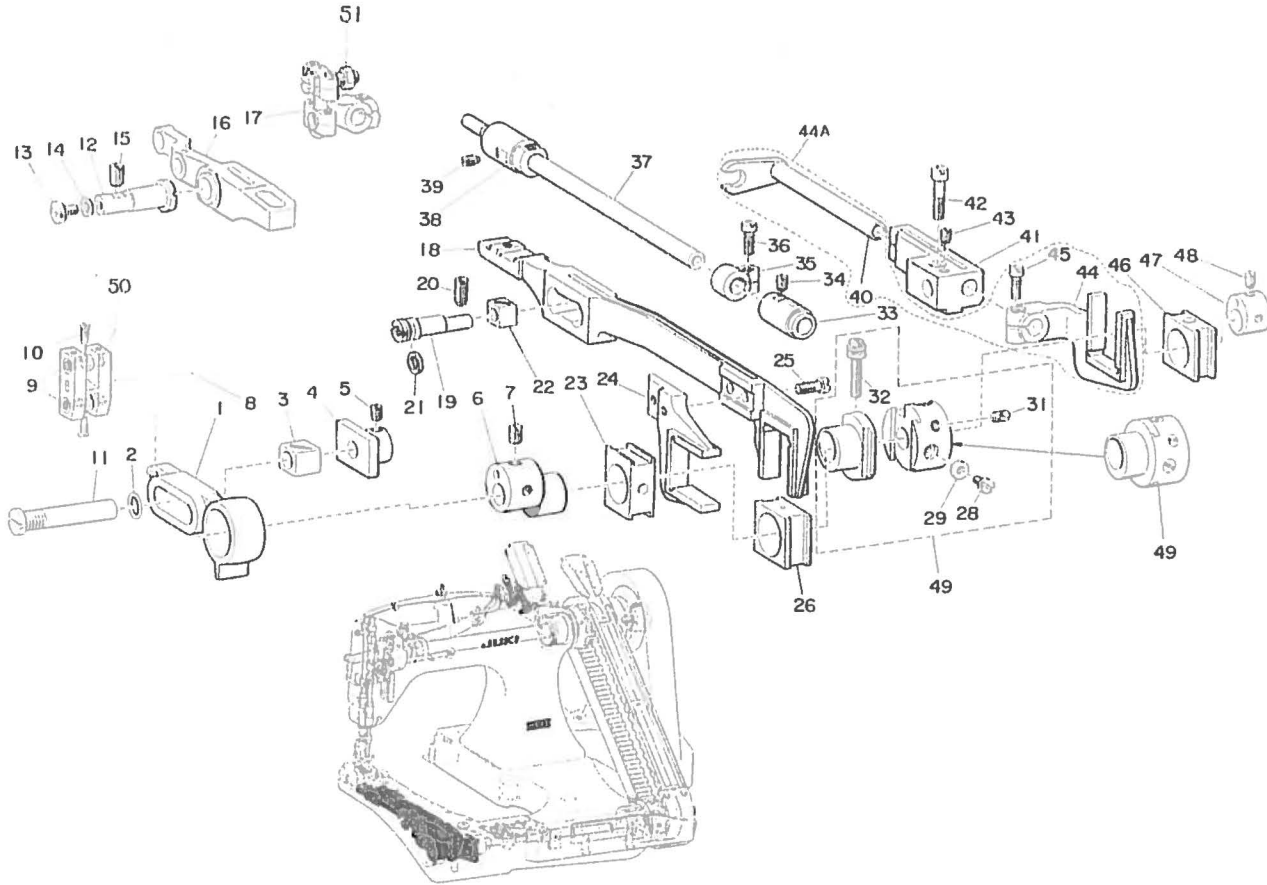

Ref. No.	Part No.	Description	Amt. Req.	Ref. No.	Part No.	Description	Amt. Req.
1	B-2101-019-000	Feed rocker & looper avoid lever	1	29	WP-0480856-SP	Washer	①
2	RO-0952001-00	O ring, for feed rocker slide block pin	1	31	SS-8151150-SK	Screw	②
3	B-2105-019-000	Feed rocker slide block	1	32	B-1614-019-000	Feed regulating screw	①
4	B-2108-019-000	Feed rocker slide block stopper	1	33	B-2503-019-000	Looper rocker shaft rear bushing	1
5	SS-8110510-SP	Screw	2	34	SS-B150410-SP	Screw	1
6	B-2103-019-000	Feed rocker eccentric	1	35	B-2505-019-000	Looper avoiding eccentric forked connection crank	1
7	SS-8660610-SP	Screw	2	36	SS-7111110-TP	Clamp screw	1
*8	B-2115-019-0A0	Feed rocker connecting link with pin	1	37	B-2501-019-000	Looper rocker shaft	1
9	B-2116-019-000	Feed rocker connecting link pin	②	38	B-2502-019-000	Looper rocker shaft front bushing	1
10	B-2117-019-000	Screw	②	39	SS-8151150-SP	Screw	1
11	B-2106-019-000	Feed rocker slide block pin	1	*44A	B-2004-019-0A0	Looper avoiding eccentric forked connection (assembly)	1
12	B-2107-019-000	Feed rocker shaft	1	40	B-2001-019-000	Looper avoiding eccentric forked connection bracket shaft	①
13	SS-7110830-SP	Clamp screw	1	41	B-2002-019-000	Looper avoiding eccentric forked connection bracket	①
14	B-2122-019-000	Washer	1	44	B-2004-019-000	Looper avoiding eccentric forked connection	①
15	SS-8150710-SP	Screw	1	45	SS-7111110-TP	Clamp screw	①
16	B-2102-019-000	Feed rocker	1	42	SS-6121840-SP	Screw	1
17	B-2109-019-0A0	Feed rocker connecting rod assembly	1	43	SS-8150410-SP	Screw, for feed rocker slide block pin	1
18	B-1601-019-000	Feed bar	1	46	B-1607-019-000	Looper avoiding eccentric forked connection slide block	1
19	B-1608-019-000	Feed bar hinge pin	1	47	B-2006-019-000	Looper avoiding eccentric	1
20	SS-8151150-SK	Screw	1	48	SS-8110410-TP	Screw	2
21	B-1617-019-000	Washer (gasket)	1				
22	B-1610-019-000	Feed bar hinge pin slide block	1				
23	B-1607-019-000	Feed lifting eccentric forked connection slide block	1				
24	B-1602-019-000	Feed lifting eccentric forked connection	1				
25	SS-7111110-TP	Screw	1				
26	B-1606-019-000	Feed eccentric slide block	1				
*49	B-1611-019-0A0	Feed eccentric adjusting base assembly	1				
28	SS-7090610-SK	Screw	①				

From the library of: Superior Sewing Machine & Supply LLC

4. ARM ROTARY SHAFT & BED ROTARY SHAFT COMPONENTS

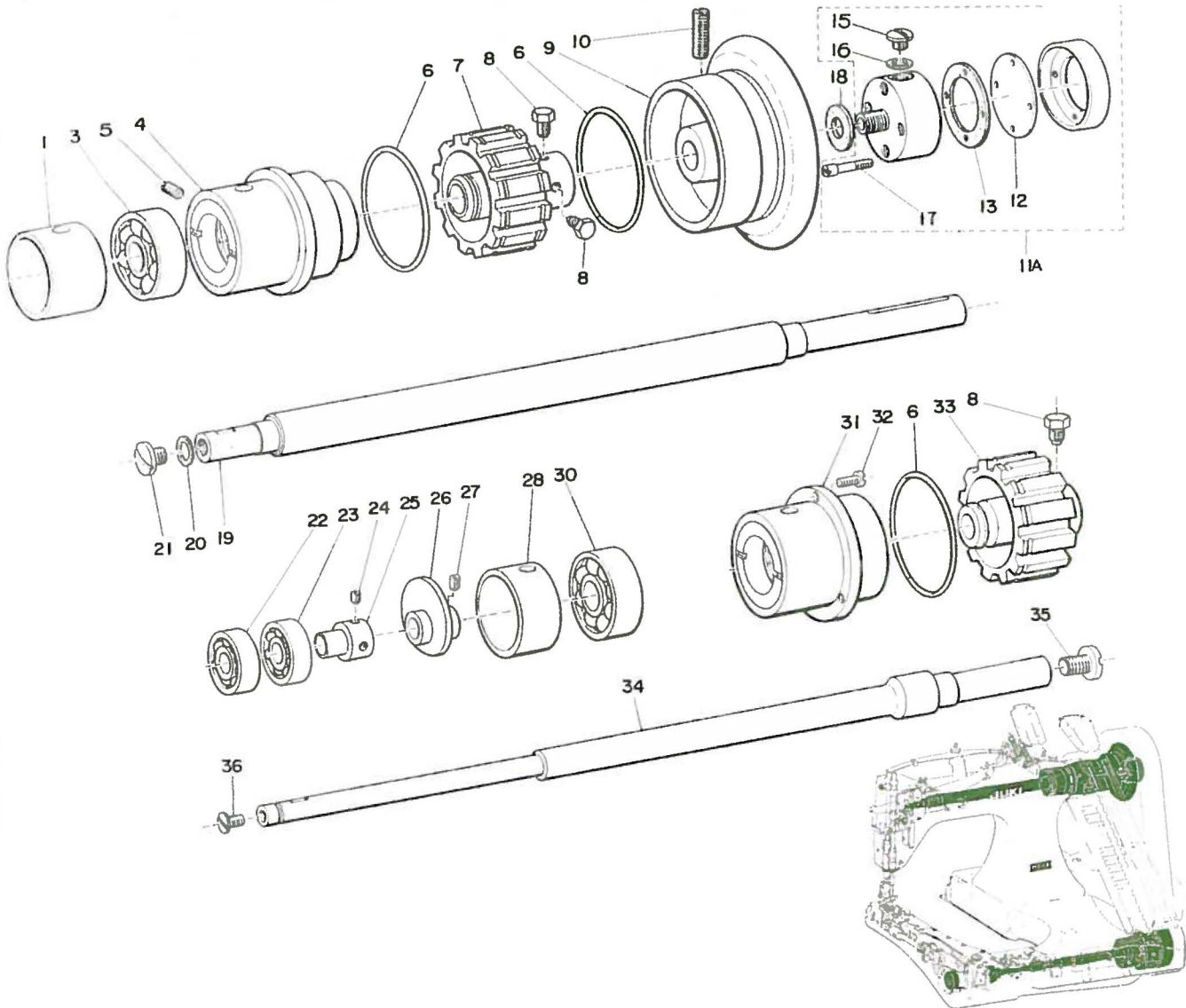

Ref. No.	Part No.	Description	Amt. Req.	Ref. No.	Part No.	Description	Amt. Req.
1	B-1204-019-000	Arm rotary shaft ball bearing spacing collar	1	24	SS-8110320-SP	. . . Screw	2
3	B-1202-019-000	Arm rotary shaft ball bearing, rear	1	25	B-1808-019-000	. . . Sleeve	1
4	B-1203-019-0A0	Arm rotary shaft ball bearing case	1	26	B-2210-019-000	Looper thread take-up	1
5	SS-8701140-SP	. . . Screw	1	27	SS-8660330-SP	. . . Screw	2
6	B-1214-019-000	Sprocket ring	3	28	B-1B11-019-000	Bed rotary shaft ball bearing spacing collar	1
7	B-1211-019-000	Sprocket wheel (A)	1	30	B-1202-019-000	Bed rotary shaft ball bearing, rear	1
8	SS-9150860-SK	. . . Screw	4	31	B-1B10-026-0A0	Bed rotary shaft ball bearing case	1
9	B-1215-026-000	Hand wheel	1	32	SS-8701140-SP	. . . Screw	1
10	SS-8152030-SP	. . . Screw	2	33	B-1212-019-000	Sprocket wheel (B)	1
*11A	B-3501-019-0A0	Oil cup body (assembly)	1	34	B-1801-019-000	Bed rotary shaft	1
12	B-3502-019-000	Oil cup body cap	①	35	SS-7161040-SP	Screw, for bed rotary shaft, rear	1
13	B-3503-019-000	Oil cup body cap gasket	①	36	SS-7110830-SP	Screw, for bed rotary shaft, front	1
15	SS-5660440-SP	Oil cup body oil plug screw	①				
16	B-3508-019-000	. . . Washer	①				
17	SS-6092120-SP	. . . Screw	4				
18	B-3505-019-000	Oil cup gasket	1				
19	B-1201-019-000	Arm rotary shaft	1				
20	B-1222-019-000	Arm rotary shaft screw washer	1				
21	SS-7740740-SP	Arm rotary shaft screw	1				
22	B-1802-019-000	Bed rotary shaft ball bearing, front	1				
23	B-1803-019-000	Bed rotary shaft ball bearing, intermediate	1				

5. THREAD TENSION & PRESSER LIFTER COMPONENTS

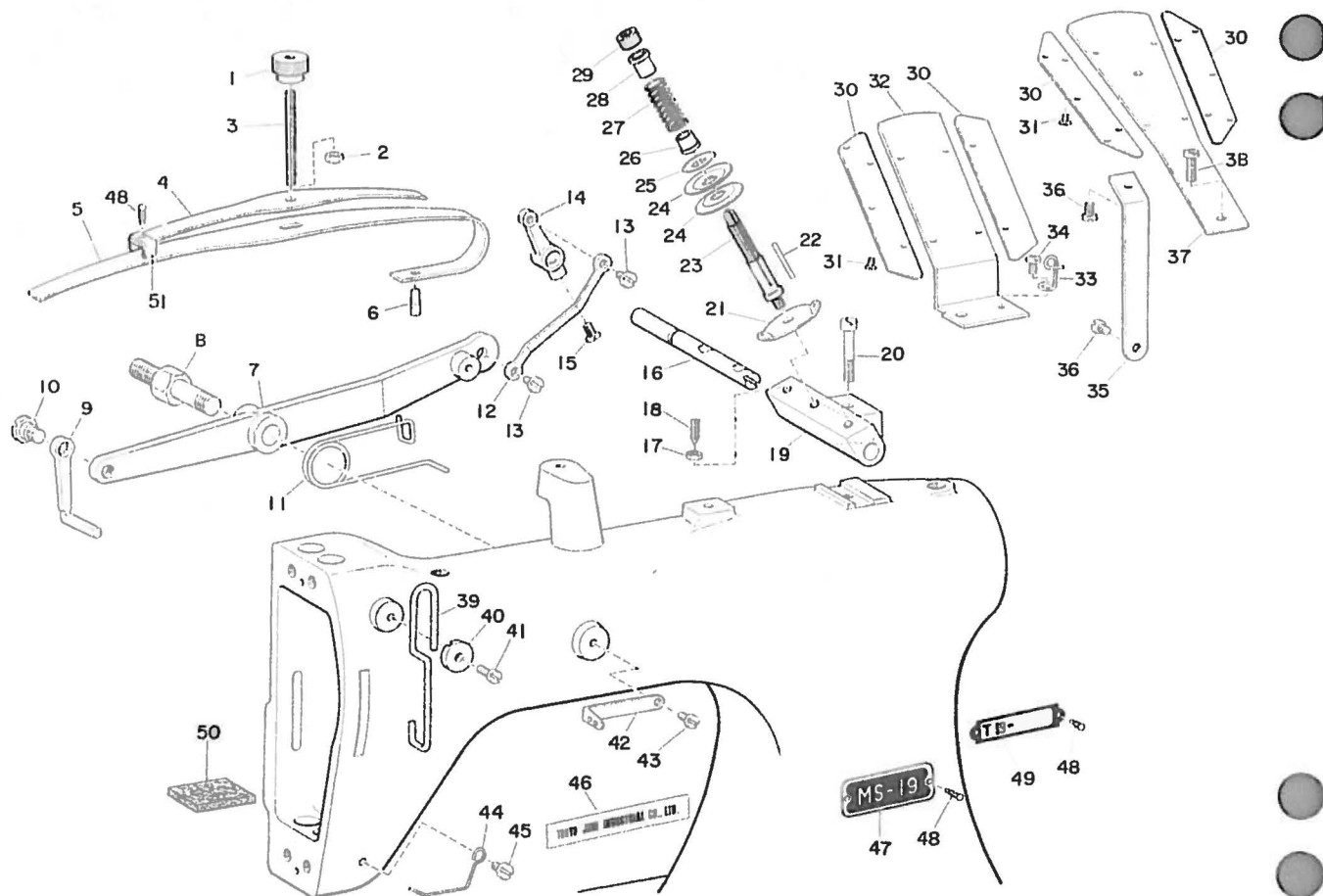

Ref. No.	Part No.	Description	Amt. Req.	Ref. No.	Part No.	Description	Amt. Req.
1	B-2326-019-000	Pressure regulating screw nut (B)	1	30	B-2402-019-000	Thread guide	4
2	NS-6120310-SP	Pressure regulating screw nut (A)	1	31	SS-5060410-SP	. . . Screw	8
3	B-2324-019-000	Pressure regulating screw	1	32	B-2420-019-000	Thread guide bracket (needle)	1
4	B-2329-019-000	Presser bar spring, upper	1	33	B-2421-019-000	Thread eyelet (needle thread)	1
5	B-2327-019-000	Presser bar spring	1	34	SS-7090510-SP	. . . Screw	1
6	B-2328-019-000	Presser bar spring pin	1	35	B-2404-019-000	Thread guide bracket support	1
7	B-2319-019-000	Presser bar lifting lever	1	36	SS-7090520-SP	. . . Screw	2
8	B-3701-019-000	. . . Hinge screw	1	37	B-2401-019-000	Thread guide bracket (looper thread)	1
9	B-2322-019-000	Presser bar lifting bracket lifter	1	38	SS-4091010-SP	. . . Screw	2
10	SD-0790431-SP	. . . Hinge screw	1	39	B-1903-019-000	Thread take-up tension lever	1
11	B-2321-019-000	Presser bar lifting lever spring	1	40	B-1904-019-000	. . . Washer	1
12	B-2315-019-000	Tension releasing shaft crank connecting link	1	41	SS-7090710-SP	. . . Screw	1
13	SD-0450211-SP	. . . Hinge screw	2	42	B-1146-019-000	Frame thread guide	1
14	B-2317-019-000	Tension releasing shaft crank	1	43	SS-4090610-SP	. . . Screw	1
15	SS-7110710-SP	. . . Screw	1	44	B-1414-019-000	Needle bar thread guide	1
16	B-2303-019-000	Tension releasing shaft	1	45	SS-7090710-SP	. . . Screw	1
17	NS-6110310-SP	. . . Lock nut	1	46	B-1159-041-000	Medallion	1
18	SS-B111160-SP	. . . Screw	1	47	B-1153-019-000	Model plate	1
19	B-2301-019-000	Tension bracket(needle thread)	1	48	A-1161-001-00B	Rivet, for model plate & number plate	1
20	SS-4622340-SP	. . . Screw	1	49	B-1199-019-000	Number plate	1
21	B-2306-019-000	Tension thread guide	2	50	B-3510-019-000	Oil return wick	1
22	B-2310-019-000	Tension releasing pin	2				
23	B-2307-019-000	Tension post	2				
24	B-3126-012-000	Tension disc	4				
25	8-3132-012-000	Tension releasing disc	2				
26	B-2313-019-000	Tension spring bushing (B)	2				
27	B-2311-019-000	Tension spring	2				
28	B-2312-019-000	Tension spring bushing (A)	2				
29	B-2314-019-000	Tension regulating thumb nut	2				

6. LOOPER MECHANISM COMPONENTS

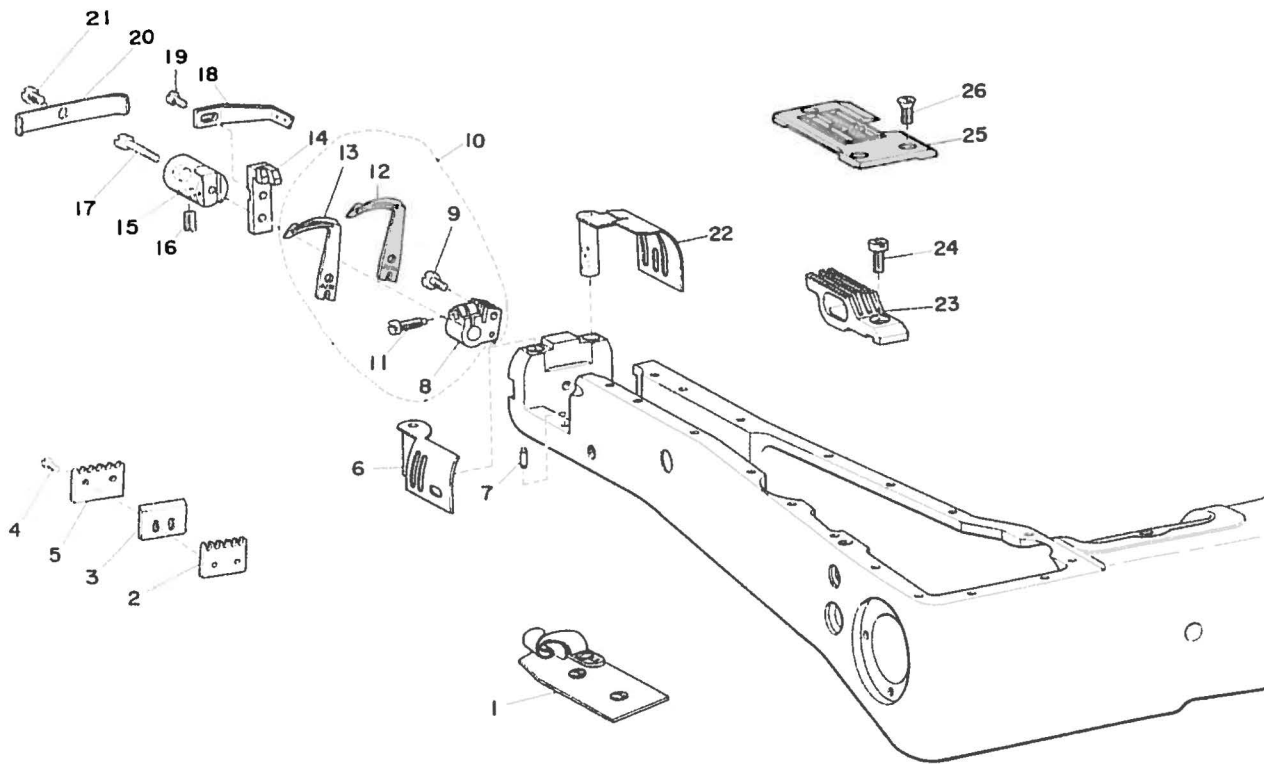

Ref. No.	Part No.	Description	Amt. Req.
1	B-9100-019-0A0	Lap seam feller assembly	1
2	B-1137-019-000	Thread cutter holding plate, inner	2
3	B-1135-019-000	Thread cutter	1
4	SS-3060710-SP	. . . Screw	2
6	B-1163-019-0A0	Looper cover, left assembly	1
7	B-1167-019-000	. . . Guide pin	1
8	B-2515-019-000	Looper holder	1
9	SS-7091480-SK	Looper clamp screw	1
10	B-2513-019-DA0	Looper assembly	(1)
11	SS-6111040-SP	Looper holder clamp screw	1
12	B-2514-019-000	Looper (B)	1
13	B-2513-019-000	Looper (A)	1
14	B-2507-019-000	Needle guard	1
15	B-2509-019-000	Needle guard holder	1
16	SS-B150410-SP	. . . Screw	1
17	SS-7092360-SP	Screw, for needle guard	1
18	B-2510-019-000	Looper thread eyelet	1
19	SS-6080710-SP	. . . Screw	1
20	B-1166-019-000	Looper cover spring	2
21	SS-7110710-SP	. . . Screw	1
22	B-1160-019-0A0	Looper cover, right assembly	1
23	B-1604-019-000	Feed dog	1
24	SS-7621040-SP	. . . Screw	1
25	B-1108-019-000	Throat plate	1
26	SS-2110920-SP	. . . Screw	1

* MAIL CAN GET IT FOR .77¢

7. PRESSER BAR & NEEDLE BAR COMPONENTS

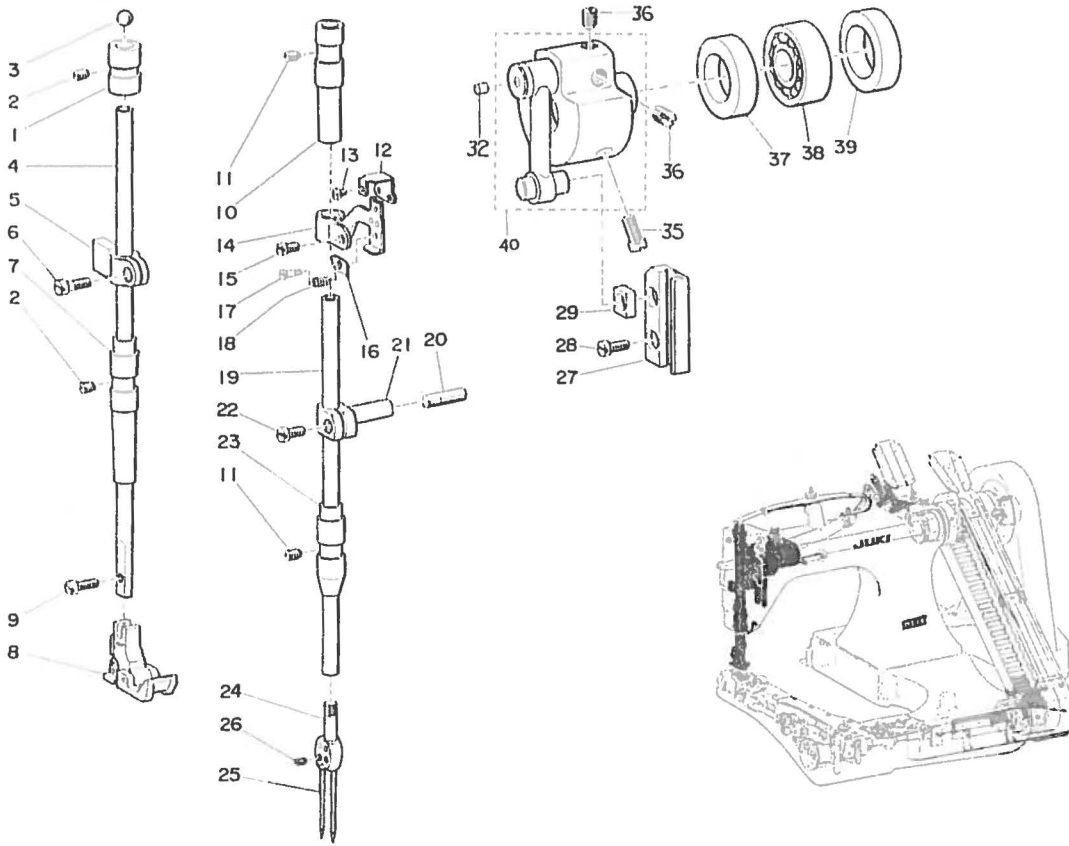

Ref. No.	Part No.	Description	Amt. Req.	Ref. No.	Part No.	Description	Amt. Req.
1	B-1502-019-000	Presser bar upper bushing	1	28	SS-7120910-SP	. . . Clamp screw	2
2	SS-8150310-SP	. . . Screw, for presser bar	2	29	B-1411-019-000	Needle bar connection slide block	1
3	B-1506-019-000	Presser bar steel ball	1	*40	B-1207-019-0A0	Counterweight assembly	1
4	B-1501-019-000	Presser bar	1	32	TA-0290601-M0	. . . Plug	①
5	B-1504-019-000	Presser bar lifting bracket	1	35	SS-6151220-SK	. . . Screw	②
6	SS-7111110-TP	. . . Clamp screw	1	36	SS-8660610-TP	Screw, for needle bar connecting link pin	②
7	B-1503-019-000	Presser bar lower bushing	1	37	B-1221-019-000	Arm rotary shaft ball bearing oil retainer (B)	1
8	B-1507-019-0A0	Presser foot assembly	1	38	B-1218-019-000	Arm rotary shaft ball bearing, front	1
9	SS-7091110-SP	. . . Screw	1	39	B-1220-019-000	Arm rotary shaft ball bearing oil retainer (A)	1
10	B-1402-019-000	Needle bar upper bushing	1				
11	SS-8150310-SP	. . . Screw, for needle bar bushing	2				
*12	B-1906-019-000	Take-up thread eyelet	1				
13	SS-3060410-SP	. . . Screw	1				
14	B-1901-019-000	Thread take-up	1				
15	SS-6090670-TP	. . . Clamp screw	1				
16	B-1908-019-000	Thread take-up tension plate	1				
17	SD-0280401-SL	. . . Screw stud	1				
18	B-1910-019-000	Thread take-up tension spring	1				
19	B-1401-019-000	Needle bar	1				
20	B-1418-019-000	Needle bar connection oil supply felt	1				
21	B-1409-019-000	Needle bar connection	1				
22	SS-7090910-SK	. . . Clamp screw	1				
23	B-1404-026-000	Needle bar lower bushing	1				
24	B-1406-019-D00	Needle clamp 3/16	1				
25	MTV-100B1600	Needle (TV x 1)	2				
26	SS-8110310-SP	. . . Screw	2				
27	B-1412-038-000	Needle bar connection slide block guide	1				

*MAIL CAN GET IT FOR .77



TOKYO JUKI INDUSTRIAL CO.,LTD.

Head Office & Plant: 2-1-8 chome, Kokuryo cho, Chofu-shi, Tokyo, Japan
Business Address: TOKYO JUKI LTD. 1-1-1, Shinjuku, TOKYO, JAPAN
Cable Address: JUKI TOKYO Telex: 232250 JUKI SHINJUKU TOK

From the library of: Superior Sewing Machine & Supply LLC